

CANTONI
MOTOR

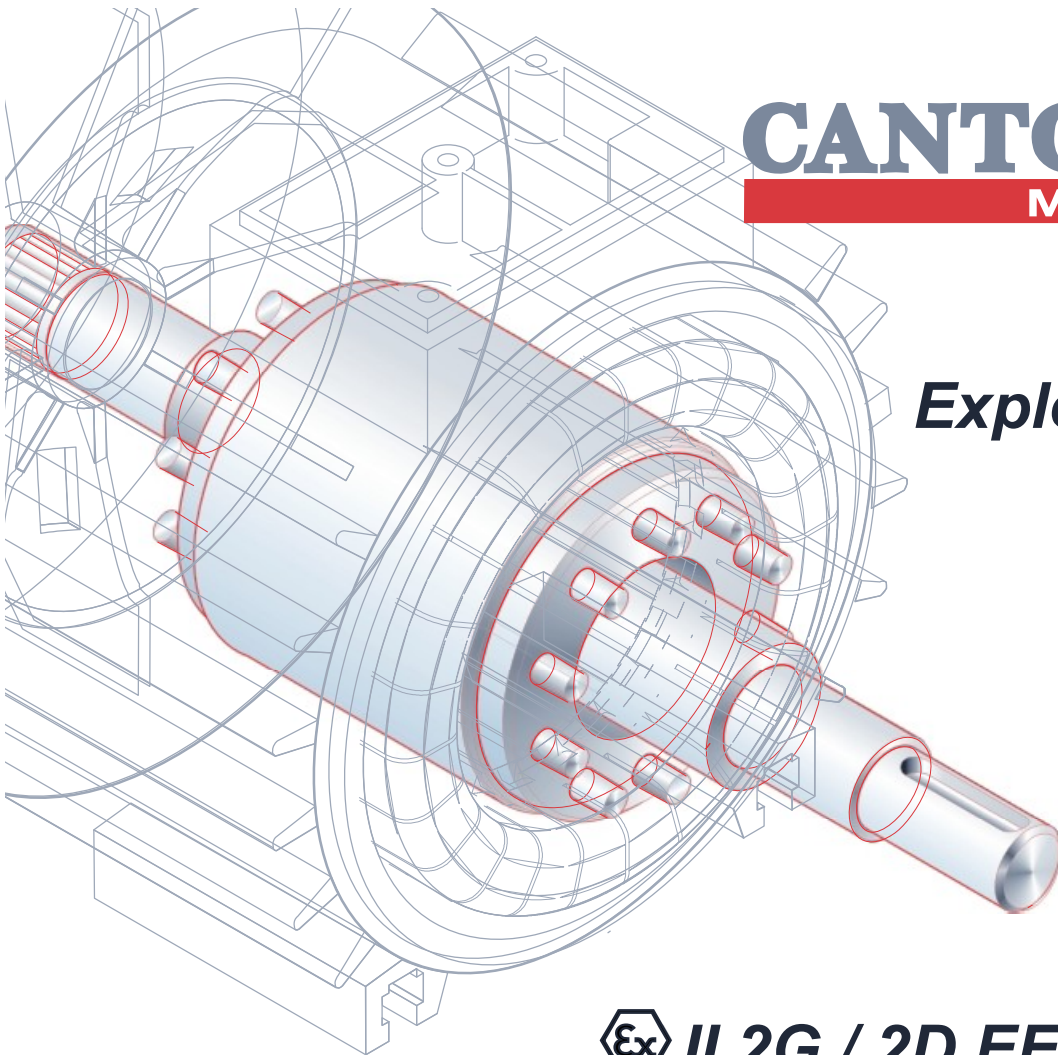

**Explosion-Proof
Motors
Increased
Safety**



Ex II 2G / 2D EExe II T3 - T4
Ex II 2G EExe II / II 2D T125°C
Ex II 2D T125°C



**Certified to
ATEX Directive 94/9/EC**

DESCRIPTION OF THE CATALOGUE VERSION

Duty type:	S1
Rated voltage:	230V, 400V
Frequency:	50 Hz
Ambient temperature:	from -20°C to + 40°C
Mounting height:	up to 1000 m above sea level
Number of free shaft ends:	1
Insulation class:	F

Explosion-proof increased safety motors are adapted for operating in areas endangered by explosion other than methane mines, (apparatus group II, explosion group II) in zone 1 (zone 21).

The EExe motors belong to the apparatus category 2G (zone 1, gas hazardous area) or 2D (zone 21, dust hazardous area) or 2G and 2D (zone 1, zone 2, zone 21, zone 22, gas and/or dust hazardous area) which means that it is either necessary to ensure that the occurrence of ignition source is excluded, or the ignition source must be encapsulated by a recognized type of protection in such a way that the ignition of an explosive atmosphere surrounding the motor is prevented.

Classification of temperature classes according to the ignition temperature of explosive atmosphere:

Ignition temperature of explosive atmosphere [°C]	Temperature class	Max. temperature of motor [°C]
Above 450	T1	450
300 - 450	T2	300
200 - 300	T3	200
135 - 200	T4	135



II specific marking of explosion protection
II for use in hazardous areas other than mines
2 apparatus category 2 for use in zone 1 (zone 21)
G for use in gas hazardous areas
D for use in dust hazardous areas
EEx built and tested according to European standards
e increased safety
II explosion group
T3 temperature class
T125°C maximal housing temperature

The motors are designed for the temperature class T3 which means that the maximum temperature of any part of the motor can not exceed + 200°C or for the temperature class T4 where maximum temperature can not exceed + 135°C.

IDENTIFICATION, BEARINGS, DEGREE OF PROTECTION

Motor Type	Bearings	Increased Safety Gas Hazardous Area	Degree of Protection	Increased Safety Dust Hazardous Area	Degree of Protection	Increased Safety Gas and Dust Hazardous Area	Degree of Protection
Sg 63	6202 2Z	II 2G EExe II T3-T4	IP 56	II 2D EExe II T3-T4	IP 65	-	IP 65
Sh 71	6203 2Z	II 2G EExe II T3-T4	IP 56	II 2D EExe II T3-T4	IP 65	-	IP 65
Sh 80	6204 2Z	II 2G EExe II T3-T4	IP 56	II 2D EExe II T3-T4	IP 65	-	IP 65
Sh 90	6205 2Z	II 2G EExe II T3-T4	IP 55	II 2D T125°C	IP 65	II 2G EExe II T3-T4 / II 2D T125°C	IP 65
Sg 100	6206 2Z	II 2G EExe II T3-T4	IP 55	II 2D T125°C	IP 65	II 2G EExe II T3-T4/ II 2D T125°C	IP 65
Sg 112	6306 2Z	II 2G EExe II T3-T4	IP 55	II 2D T125°C	IP 65	II 2G EExe II T3-T4/ II 2D T125°C	IP 65
Sg 132	6308 2Z	II 2G EExe II T3-T4	IP 55	II 2D T125°C	IP 65	II 2G EExe II T3-T4/ II 2D T125°C	IP 65
Sg 160	6309 2Z	II 2G EExe II T3-T4	IP 55	II 2D T125°C	IP 65	II 2G EExe II T3-T4/ II 2D T125°C	IP 65
Sg 180	6311 2Z	II 2G EExe II T3-T4	IP 55	II 2D T125°C	IP 65	II 2G EExe II T3-T4/ II 2D T125°C	IP 65

As part of our development program, we reserve the right to alter or amend any of the specifications without giving prior notice.

- In the EExe motors there are applied additional means to increase safety in case of appearance of excessive temperature or occurrence of arcs and sparks inside the motor and on its external parts. There are special terminal board, terminal box ensuring suitable insulating distances, certified cable gland, two neutral terminals, reinforced insulation etc. The parts of motor housing are made of material with magnesium contents less than 6% apart from the fan cover which is made of steel.
- The overload protection of the motor must cause the motor to disconnect from the supply voltage in a time shorter than the specified time t_E when the current is equal to the starting current. Time t_E is the time when, during the flow of the starting current, the motor winding heats up to the limit temperature from the temperature of rated conditions at maximum ambient temperature. For t_E please refer to the table with parameters.
- The motors can be provided with a cable gland with a holder (protecting the supply wire against pulling out). The motors that are provided with special fan cover can work in perpendicular position with the shaft down, However detailed conditions specified in service manual being enclosed to each motor, must be fulfilled.
- The motors II 2D T125°C are equipped with posistor-based PTC temperature sensors. During normal operation within the nominal range, temperatures of motor component external surfaces do not exceed 125 °C. The user must install the equipment compliant with PTC sensors. The equipment should cut power off if motor temperature is exceeded. Motor overheating may be caused by its overload, shaft locking, motor failure, etc.

STANDARDS

The electric motors are manufactured according to international standards:

Electrical requirements	EN 600 34-1 EN 600 34-6 EN 600 34-9
Mechanical requirement	EN 600 34-5, EN 60529 EN 600 34-6 EN 600 34-7 EN 600 34-14 IEC 72-1, EN 50347

The motors meet requirements of EN 50014, EN-50019 and EN 13980 (production quality requirements).

The products comply with the specifications regarding the electromagnetic compatibility specified in:
EN 50081-1, EN 50081-2, EN 50082-1, EN 50082-2.

“II 2D T125°C” range motors meet also requirements of EN 50281-1-1: 1998 + A1

Each motor is manufactured according to requirements of ATEX Directive 94/9/EC and has a certificate of conformity with the documentation approved by N.V. KEMA, Netherlands.

Type Sg63.-	KEMA 03 ATEX2176 for temperature class T3 KEMA 03 ATEX2177 for temperature class T4
Type Sh71.-	KEMA 03 ATEX2178 for temperature class T3 KEMA 03 ATEX2179 for temperature class T4
Type Sh80.-	KEMA 03 ATEX2180 for temperature class T3 KEMA 03 ATEX2181 for temperature class T4
Type Sh90.-	KEMA 02 ATEX2136 for temperature class T3 KEMA 02 ATEX2137 for temperature class T4
Type Sg100.-	KEMA 02 ATEX2138 for temperature class T3 KEMA 02 ATEX2139 for temperature class T4
Type Sg112.-	KEMA 02 ATEX2140 for temperature class T3 KEMA 02 ATEX2141 for temperature class T4
Type Sg132.-	KEMA 02 ATEX2142 for temperature class T3 KEMA 02 ATEX2143 for temperature class T4
Type Sg160.-	KEMA 02 ATEX2144 for temperature class T3 KEMA 02 ATEX2145 for temperature class T4
Type Sg 180.-	KEMA 02 ATEX2146 for temperature class T3 KEMA 02 ATEX2147 for temperature class T4
“II 2D T125°C” range	KEMA 06 ATEX0113

All the motors are manufactured in Quality Assurance System consistent with ISO 9001.



The motors covered by the present catalogue comply with the regulations and standards consistent with IEC standards.



All the motors described in present catalogue are provided with CE mark. It means that our products are consistent with the European Union directives regarding the safety features.



Totally Enclosed Motors
Insulation Class F

II 2G EExe II T3 -T4 (frame size: 56 - 180)

II 2D EExe II T3 -T4 (frame size: 56 - 80)

II 2G EExe II / II 2D T125°C (frame size: 80 - 180)



TECHNICAL DATA

Item	Type of Motor	Rated Output		Rated Speed n_N [rpm]	Rated Torque T_N [Nm]	Rated Efficiency η_N [%]	Power Factor $\cos\varphi_N$ [-]	Full-Load Amps at Rated Voltage		Locked Rotor Torque T_L/T_N [-]	Locked Rotor Current I_L/I_N [-]	Breakdown Torque T_b/T_N [-]	Heating Time t_E		Weight (IMB3) m kg
		P_N [kW]	[HP]					I_N [A] _{230V}	[A] _{400V}				T3	T4	
		2p=2 $n_s=3000$ rpm													
1.	ExSg56-2A-T3	0,09	0,12	2800	0,31	58	0,68	0,58	0,33	2,3	3,7	2,4	50	-	2,9
2.	ExSg56-2A-T4	0,09	0,12	2800	0,31	58	0,68	0,58	0,33	2,3	3,7	2,4	-	20	2,9
3.	ExSg56-2B-T3	0,12	0,16	2810	0,41	60	0,62	0,81	0,47	2,7	3,9	2,7	40	-	3,2
4.	ExSg56-2B-T4	0,12	0,16	2810	0,41	60	0,62	0,81	0,47	2,7	3,9	2,7	-	15	3,2
5.	ExSg63-2A-T3	0,18	0,25	2710	0,63	61	0,82	0,9	0,5	1,9	4	1,9	39,5	-	3,6
6.	ExSg63-2A-T4	0,18	0,25	2710	0,63	61	0,82	0,9	0,5	1,9	4	1,9	-	14,0	3,6
7.	ExSg63-2B-T3	0,25	0,33	2770	0,86	64	0,82	1,2	0,7	2	4,4	2	25,8	-	4,2
8.	ExSg63-2B-T4	0,18	0,25	2840	0,61	62	0,72	1,1	0,6	2,8	5,2	2,8	-	11,5	4,2
9.	ExSh71-2A-T3	0,37	0,5	2680	1,32	59	0,9	1,75	1	2,2	4	2,2	18,2	-	5
10.	ExSh71-2A-T4	0,25	0,33	2830	0,84	65	0,8	1,2	0,7	2,8	5,4	3	-	11,8	5
11.	ExSh71-2B-T3	0,55	0,75	2720	1,93	67	0,86	2,4	1,4	2	4,4	2,1	12	-	6
12.	ExSh71-2B-T4	0,37	0,5	2850	1,24	70	0,75	1,75	1	2,9	5,8	3	-	8,8	6
13.	ExSh80-2A-T3	0,75	1	2760	2,6	73	0,83	3,1	1,8	2,7	4,7	2,6	10,5	-	8
14.	ExSh80-2A-T4	0,55	0,75	2850	1,85	71	0,78	2,45	1,4	2,8	6	2,9	-	6,2	8
15.	ExSh80-2B-T3	1,1	1,5	2780	3,7	75	0,88	4,15	2,4	2,6	5,5	2,6	7,2	-	9,1
16.	Sh90S-2-T3	1,5	2	2850	5	77,8	0,81	6,1	3,5	2,9	6	3	10	-	12,5
17.	Sh90S-2-T4	1	1,36	2895	3,3	79,6	0,78	4	2,3	3,8	7,5	4,1	-	6	12,7
18.	Sh90L-2-T3	2,2	3	2860	7,35	81,7	0,82	8,2	4,7	3	7,1	3,2	5	-	15,9
19.	Sh90L-2-T4	1,2	1,6	2855	4	79,5	0,9	4,2	2,4	3,2	7,4	3,2	-	6	16,5
20.	Sg100L-2-T3	2,4	3,3	2905	7,9	81,7	0,88	8,3	4,8	2,7	8,3	3	6	-	22,8
21.	Sg100L-2-T4	1,5	2	2900	4,9	79,2	0,91	5,2	3	2,8	7,8	3,1	-	5,5	22,5
22.	Sg112M-2-T3	4	5,5	2875	13,3	85,5	0,91	13	7,5	2	6,5	2,4	8	-	33
23.	Sg112M-2-T4	2	2,7	2915	6,5	85,8	0,91	6,4	3,7	3	7,9	3,5	-	15	33
24.	Sg132S-2A-T3	5,5	7,5	2915	18	85,3	0,9	18,1	10,4	2,4	7,1	2,7	9	-	57
25.	Sg132S-2A-T4	2,5	3,4	2930	8,1	85,2	0,91	8	4,6	2,4	7,5	3,2	-	16	58
26.	Sg132S-2B-T3	7	9,4	2920	22,9	87,3	0,91	22,1	12,7	2,5	7,7	3,1	7	-	76
27.	Sg132S-2B-T4	3,5	4,8	2935	11,4	86,1	0,92	11,1	6,4	2,8	8	3,4	-	11	72
28.	Sg160M-2A-T3	11	15	2920	36	88,1	0,89	35	20,1	2,3	6,5	2,7	5,6	-	101
29.	Sg160M-2A-T4	5	6,8	2945	16,2	87,7	0,9	16	9,2	3	7,7	3,6	-	8	101
30.	Sg160M-2B-T4	6	8,1	2950	19,4	88,7	0,91	18,6	10,7	2,9	7,7	3,3	-	7	112
31.	Sg160L-2-T3	16	21,4	2940	52	90,8	0,9	49,2	28,3	2,8	7,7	3,5	7	-	132
32.	Sg160L-2-T4	7,5	10	2950	24,3	90	0,92	22,8	13,1	3,2	7,8	3,5	-	8	129
33.	Sg180M-2-T3	18,5	25	2945	60	91,6	0,92	55,3	31,8	2,3	8,25	3,4	13	-	188
34.	Sg180M-2-T4	10	13,6	2950	32,4	90,4	0,92	30,3	17,4	2,4	8,5	3,6	-	14	191
2p=4 $n_s=1500$ rpm															
35.	ExSg56-4A-T3	0,06	0,82	1400	0,41	53	0,60	0,47	0,27	1,8	3,3	2	80	-	2,9
36.	ExSg56-4A-T4	0,06	0,82	1400	0,41	53	0,60	0,47	0,27	1,8	3,3	2	-	35	2,9
37.	ExSg56-4B-T3	0,09	0,12	1390	0,62	55	0,62	0,66	0,38	1,9	3,1	2	55	-	3,2
38.	ExSg56-4B-T4	0,09	0,12	1390	0,62	55	0,62	0,66	0,38	1,9	3,1	2	-	21	3,2
39.	ExSg63-4A-T3	0,12	0,17	1380	0,83	50	0,67	0,9	0,5	2	3,4	2	50,3	-	3,6
40.	ExSg63-4A-T4	0,12	0,17	1380	0,83	58	0,67	0,9	0,5	2	3,4	2	-	18,6	3,6
41.	ExSg63-4B-T3	0,18	0,25	1370	1,25	62	0,69	1,1	0,6	2	3,7	2	41,1	-	4,2
42.	ExSg63-4B-T4	0,18	0,25	1370	1,25	62	0,69	1,1	0,6	2	3,7	2	-	14,2	4,2
43.	ExSh71-4A-T3	0,25	0,33	1350	1,77	65	0,69	1,4	0,8	2	3,7	2	41,7	-	4,8
44.	ExSh71-4A-T4	0,18	0,25	1400	1,23	66	0,57	1,2	0,7	2,7	4,2	2,7	-	19,2	4,8
45.	ExSh71-4B-T3	0,37	0,5	1350	2,62	68	0,59	2,25	1,3	2	3,6	2	20,4	-	5,9
46.	ExSh80-4A-T3	0,55	0,75	1370	3,8	71	0,72	2,75	1,6	1,7	3,4	1,8	16,5	-	7,8
47.	ExSh80-4A-T4	0,37	0,5	1420	2,5	72	0,58	2,25	1,3	2,5	4,1	2,7	-	11	7,8
48.	ExSh80-4B-T3	0,75	1	1370	5,2	71	0,74	3,7	2,1	1,8	4,6	1,8	20	-	9
49.	ExSh80-4B-T4	0,55	0,75	1420	3,7	74	0,64	2,95	1,7	2,5	5,5	2,5	-	11,5	9
50.	Sh90S-4-T3	1,1	1,5	1405	6,8	72,9	0,8	4,7	2,7	2	4,65	2,4	14	-	12,7
51.	Sh90S-4-T4	0,8	1,07	1435	5,3	75,8	0,75	3,5	2	2,6	5,7	3,1	-	10	12,7
52.	Sh90L-4-T3	1,5	2	1415	10,1	75,5	0,77	6,4	3,7	2,5	5,3	2,7	13	-	15,5
53.	Sh90L-4-T4	1,1	1,5	1430	7,3	76	0,78	4,7	2,7	2,8	6,2	3	-	10	16

Totally Enclosed Motors
Insulation Class F



II 2G EExe II T3 -T4 (frame size: 56 - 180)
II 2D EExe II T3 -T4 (frame size: 56 - 80)
II 2G EExe II / II 2D T125°C (frame size: 80 - 180)

Item	Type of Motor	Rated Output		Rated Speed	Rated Torque	Rated Efficiency	Power Factor	Full-Load Amps at Rated Voltage		Locked Rotor Torque	Locked Rotor Current	Breakdown Torque	Heating Time t _e		Weight (IMB3)
		P _N						η _N	T _N				η _N	cos φ _N	
		[kW]	[HP]	[rpm]	[Nm]	[%]	[-]	[A] _{230V}	[A] _{400V}	[-]	[-]	[-]	[s]	[s]	kg
2p=4 n _s =1500 rpm															
54.	Sg100L-4A-T3	2,2	3	1425	14,7	77,1	0,8	9	5,2	2,4	5,9	2,8	9	-	21,9
55.	Sg100L-4A-T4	1,5	2	1430	10	78,1	0,83	5,7	3,3	2,6	6,2	3,1	-	10	22,1
56.	Sg100L-4B-T3	3	4	1415	20,2	78	0,81	12	6,9	2,6	5,75	2,9	9	-	24
57.	Sg100L-4B-T4	2	2,7	1425	13,4	79,8	0,85	7,5	4,3	2,4	6,2	2,7	-	7	23,9
58.	Sg112M-4-T3	4	5,5	1430	26,7	82,6	0,85	14,4	8,3	2,5	6,9	3	7	-	33
59.	Sg112M-4-T4	2,4	3,3	1450	15,8	83,8	0,84	8,5	4,9	3	7,9	3,7	-	8	33
60.	Sg132S-4-T3	5,5	7,5	1455	36,1	84,5	0,84	19,3	11,1	2,2	6,8	2,8	7	-	60
61.	Sg132S-4-T4	3	4	1465	19,5	85,5	0,85	10,4	6	2,3	7,7	3	-	8	60
62.	Sg132M-4-T3	7,5	10	1450	49,4	85,9	0,86	25,4	14,6	2,3	7	2,8	5	-	71
63.	Sg132M-4-T4	4	5,5	1460	26,2	86,2	0,87	13,4	7,7	2,2	7,4	3	-	7	71
64.	Sg160M-4-T3	11	15	1460	72	88,5	0,85	36,7	21,2	2,2	7,2	3,1	9	-	104
65.	Sg160M-4-T4	6	8,1	1465	39,1	88,6	0,87	19,7	11,3	2	7,3	2,8	-	14	105
66.	Sg160L-4-T3	15	20	1460	98,1	89,7	0,86	48,7	28	2,3	7,4	3	8	-	126
67.	Sg160L-4-T4	7,5	10	1465	48,9	89,4	0,88	24	13,8	2,2	7,6	2,9	-	12	127
68.	Sg180M-4-T3	18,5	25	1470	120	91,4	0,89	57,4	33	2,8	7,9	2,7	5	-	173
69.	Sg180L-4-T3	22	30	1465	143	91,7	0,9	66,6	38,3	2,8	7,7	2,6	5	-	200
70.	Sg180L-4-T4	11	15	1465	71,7	89,8	0,92	33,6	19,3	2	5,8	2,3	-	7	199
2p=6 n _s =1000 rpm															
71.	ExSh71-6A-T3	0,18	0,25	890	1,93	49	0,66	1,4	0,8	1,9	2,8	1,9	26	-	4,9
72.	ExSh71-6B-T3	0,25	0,33	870	2,74	51	0,7	1,75	1	1,6	2,8	1,6	22,1	-	5,8
73.	ExSh80-6A-T3	0,37	0,5	910	3,9	62	0,66	2,25	1,3	2	3	2,1	30	-	7,3
74.	ExSh80-6B-T3	0,55	0,75	880	5,9	65	0,72	2,95	1,7	1,9	3,1	2	22	-	8,6
75.	ExSh80-6B-T4	0,37	0,5	940	3,75	68	0,6	2,25	1,3	2,7	4	3	-	18	8,9
76.	Sh90S-6-T3	0,75	1	915	7,82	69,8	0,73	3,7	2,1	1,9	3,7	2,1	32	-	12,1
77.	Sh90S-6-T4	0,65	0,88	935	6,6	71,1	0,68	3,5	2	2,3	4,1	2,6	-	18	12,4
78.	Sh90L-6-T3	1,1	1,5	920	11,4	73,3	0,71	5,2	3	2,2	4,05	2,5	33	-	15,5
79.	Sh90L-6-T4	0,8	1,07	950	8	73,9	0,61	4,5	2,6	3,1	4,8	3,3	-	18	15,5
80.	Sg100L-6-T3	1,5	2	945	15,2	72,5	0,73	7,1	4,1	2,1	4,5	2,4	17	-	21
81.	Sg100L-6-T4	1,2	1,6	950	12,1	73,7	0,74	5,6	3,2	2,3	4,8	2,7	-	12	22,1
82.	Sg112M-6-T3	2,2	3	960	21,9	81,2	0,77	8,9	5,1	2,3	5,9	2,7	19	-	32
83.	Sg112M-6-T4	1,6	2,1	970	15,7	81,1	0,73	6,8	3,9	2,8	6,7	3,4	-	12	32
84.	Sg132S-6-T3	3	4	945	30,3	79,7	0,8	11,8	6,8	2,1	5,3	2,8	18	-	52
85.	Sg132S-6-T4	2,2	3	960	21,9	80,7	0,78	8,9	5,1	2,3	5,9	3	-	11	52
86.	Sg132M-6A-T3	4	5,5	950	40,2	82,9	0,82	14,8	8,5	2,3	6,1	2,9	14	-	64
87.	Sg132M-6A-T4	2,8	3,8	960	27,8	84,3	0,8	10,4	6	2,4	6,5	2,9	-	12	63
88.	Sg132M-6B-T3	5,5	7,5	950	55,3	83,3	0,82	20,2	11,6	2,7	6,4	3,4	8	-	71
89.	Sg132M-6B-T4	4	5,5	960	39,8	84,8	0,83	14,3	8,2	2,5	7	3,5	-	5,5	71
90.	Sg160M-6-T3	7,5	10	960	74,6	86,3	0,8	27,3	15,7	2,2	6,5	2,8	10	-	99
91.	Sg160M-6-T4	5,5	7,5	965	54,4	87,2	0,81	19,5	11,2	2,2	6,7	2,9	-	7	101
92.	Sg160L-6-T3	11	15	960	109,4	87,5	0,82	38,3	22	2,3	6,8	3,3	8	-	126
93.	Sg160L-6-T4	7	9,4	970	68,9	88,6	0,84	23,7	13,6	2,4	7,5	3,1	-	8	125
94.	Sg180L-6-T3	13,5	18	980	131	89,3	0,82	46,3	26,6	3,2	6,7	2,4	8	-	169

TECHNICAL DATA

Totally Enclosed Motors
Insulation Class F
II 2D T 125°C



TECHNICAL DATA

Item	Type of Motor	Rated Output		Rated Speed	Rated Torque	Rated Efficiency	Power Factor	Full-Load Amps at Rated Voltage		Locked Rotor Torque	Locked Rotor Current	Breakdown Torque	Weight (IMB3)
		P_N						I_N					
		[kW]	[HP]	[A] _{230V}	[A] _{400V}								
2p=2 n_S=3000 rpm													
95.	Sh 90S-2	1,5	2	2835	5,1	81,1	0,83	5,6	3,2	3	6,15	3,05	14
96.	Sh 90L-2	2,2	3	2855	7,4	83,2	0,82	8,1	4,7	3,4	7,1	3,5	16,8
97.	Sg 100L-2	3	4	2905	9,9	83,4	0,86	10,5	6	2,7	7,5	2,8	25
98.	Sg 112M-2	4	5,5	2865	13,3	85,4	0,9	13,1	7,5	2,1	6,4	2,3	34
99.	Sg 132S-2A	5,5	7,5	2910	18,0	87	0,88	18,0	10,4	2,4	7	3,2	60
100.	Sg 132S-2B	7,5	10	2920	24,5	88,5	0,88	24,2	13,9	2,5	7,5	3,2	71
101.	Sg 160M-2A	11	15	2930	35,9	89,5	0,89	34,7	19,9	2,4	6,1	2,9	100
102.	Sg 160M-2B	15	20	2920	49,1	90,5	0,91	45,7	26,3	2,4	6,2	2,7	115
103.	Sg 160L-2	18,5	25	2930	60,3	91	0,91	56,1	32,2	2,8	6,5	3	130
104.	Sg 180M-2	22	30	2920	71,9	90,6	0,88	69,3	39,8	2,5	6	2,5	165
2p=4 n_S=1500 rpm													
105.	Sh 90S-4	1,1	1,5	1405	7,5	76,7	0,8	4,5	2,6	220	4,9	2,8	14
106.	Sh 90L-4	1,5	2	1410	10,2	79	0,78	6,1	3,5	250	5,3	2,8	16,5
107.	Sg 100L-4A	2,2	3	1425	14,7	82	0,8	8,4	4,8	250	6,1	2,8	25
108.	Sg 100L-4B	3	4	1415	20,2	82,7	0,81	11,2	6,5	260	6,1	2,7	26
109.	Sg 112M-4	4	5,5	1435	26,6	85,1	0,82	14,4	8,3	260	6,3	3	34
110.	Sg 132S-4	5,5	7,5	1450	36,2	85,9	0,84	19,1	11	220	6,9	3,1	62
111.	Sg 132M-4	7,5	10	1450	49,4	87	0,85	25,5	14,6	240	6,7	3,1	73
112.	Sg 160M-4	11	15	1460	71,9	89	0,85	36,5	21	230	7	3,1	105
113.	Sg 160L-4	15	20	1460	98,1	89,5	0,87	48,4	27,8	240	7,3	3,2	125
114.	Sg 180M-4	18,5	25	1470	120,2	90,5	0,9	57,0	32,8	240	6,8	2,9	165
115.	Sg 180L-4	22	30	1465	143,4	91	0,9	67,4	38,8	270	7,3	2,8	175
2p=6 n_S=1000 rpm													
116.	Sh 90S-6	0,75	1	915	7,8	72,4	0,72	3,6	2,1	190	3,7	2,2	13,5
117.	Sh 90L-6	1,1	1,5	920	11,4	75,4	0,71	5,2	3	220	4	2,25	16,5
118.	Sg 100L-6	1,5	2	945	15,2	76,7	0,73	6,7	3,9	190	4,6	2,3	24
119.	Sg 112M-6	2,2	3	960	21,9	83,8	0,78	8,4	4,9	220	5,9	2,8	33
120.	Sg 132S-6	3	4	950	30,2	81	0,78	11,9	6,9	210	5,4	2,8	54
121.	Sg 132M-6A	4	5,5	950	40,2	84	0,79	15,1	8,7	240	6	3,1	66
122.	Sg 132M-6B	5,5	7,5	950	55,3	85	0,79	20,6	11,8	270	6,3	3,1	72
123.	Sg 160M-6	7,5	10	960	74,6	87,5	0,81	26,6	15,3	230	6,5	3,1	100
124.	Sg 160L-6	11	15	960	109,4	88,5	0,82	38,0	21,9	240	7	3,1	125
125.	Sg 180L-6	15	20	975	146,9	89	0,84	50,4	29	280	6	2,4	170

FLANGE MOUNTED MOTORS - IM B3 / V5

II 2G EExe II T3 -T4
 II 2D EExe II T3 -T4
 II 2G EExe II / II 2D T125°C

IM B3 / V5

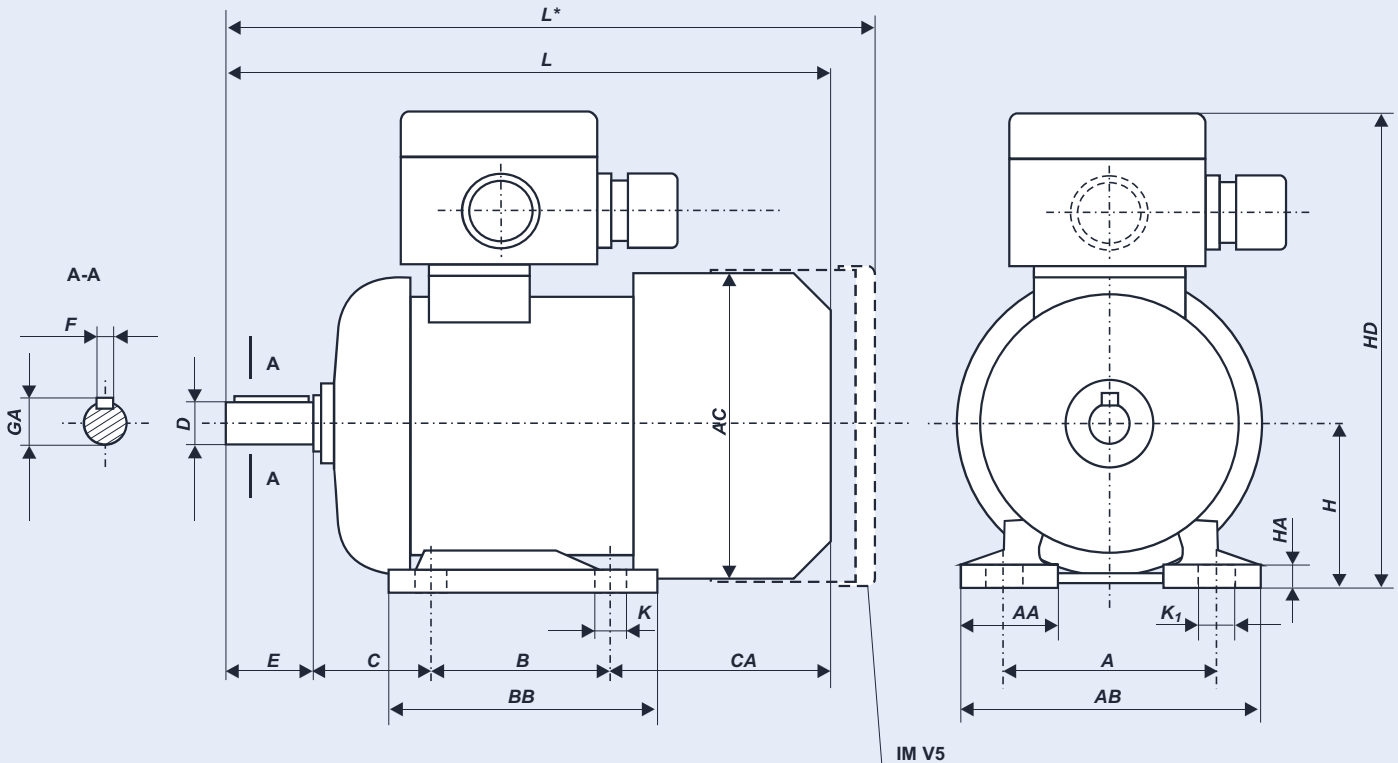

DIMENSION DRAWINGS

Type of Motor	A	B	C	CA	D	E	F	GA	H	K	K1	Gland	AA	AB	AC	BB	HA	HD	L/L*	Bearings
ExSg56-A	90	71	36	66,5	9j6	20	3h9	10,2	56	5,8	8	M20	30	110	117	92	7	176	188/214	6201 2Z
ExSg56-B	90	71	36	74,5	9j6	20	3h9	10,2	56	5,8	8	M20	30	110	117	92	7	176	196/222	6201 2Z
ExSg63-A	100	80	40	67	11j6	23	4h9	12,5	63	7	10	M20	36	124	126	106	8,5	185	202/228	6202 2Z
ExSg63-B	100	80	40	79	11j6	23	4h9	12,5	63	7	10	M20	36	124	126	106	8,5	185	214/240	6202 2Z
ExSh71-A	112	90	45	65	14j6	30	5h9	16	71	7	10	M20	45	142	141	116	8	202	223/249	6203 2Z
ExSh71-B	112	90	45	83	14j6	30	5h9	16	71	7	10	M20	45	142	141	116	8	202	245/271	6203 2Z
ExSh80-A	125	100	50	87	19j6	40	6h9	21,5	80	10	13	M20	55	160	157	130	9	222	266/283	6204 2Z
ExSh80-B	125	100	50	99	19j6	40	6h9	21,5	80	10	13	M20	55	160	157	130	9	222	278/303	6204 2Z
Sh90S-	140	100	56	104	24j6	50	8h9	27	90	10	-	M20	50	170	185	153	10	220	305/329	6205 2Z
Sh90L-	140	125	56	104	24j6	50	8h9	27	90	10	-	M20	50	170	185	153	10	220	330/354	6205 2Z
Sg100L-	160	140	63	116	28j6	60	8h9	31	100	12	-	M20	45	200	206	172	14	240	376/421	6206 2Z
Sg112M-	190	140	70	119	28j6	60	8h9	31	112	12	-	M25	54	230	245	174	14	276	384/429	6306 2Z
Sg132S-	216	140	89	160	38k6	80	10h9	41	132	12	-	M25	56	278	274	182	16	330	463/516	6308 2Z
Sg132S-2B	216	140	89	198	38k6	80	10h9	41	132	12	-	M25	56	278	274	220	16	330	501/554	6308 2Z
Sg132M-	216	178	89	160	38k6	80	10h9	41	132	12	-	M25	56	278	274	220	16	330	501/554	6308 2Z
Sg160M-	254	210	108	200	42k6	110	12h9	45	160	15	-	M40	60	305	323	256	20	370	612/665	6309 2Z
Sg160L-	254	254	108	200	42k6	110	12h9	45	160	15	-	M40	60	305	323	300	20	370	656/709	6309 2Z
Sg180M-2	279	241	121	256	48k6	110	14h9	51,5	180	15	-	M40	70	350	360	320	26	408	756/809	6311 2Z
Sg180M-4	279	241	121	243	48k6	110	14h9	51,5	180	15	-	M40	70	350	360	320	26	408	705/758	6311 2Z
Sg180L-4	279	279	121	256	48k6	110	14h9	51,5	180	15	-	M40	70	350	360	320	26	408	756/809	6311 2Z
Sg180L-6	279	279	121	243	48k6	110	14h9	51,5	180	15	-	M40	70	350	360	320	26	408	705/758	6311 2Z

FLANGE MOUNTED MOTORS - IM B5 / V1

II 2G EExe II T3 -T4

II 2D EExe II T3 -T4

II 2G EExe II / II 2D T125°C

DIMENSION DRAWINGS

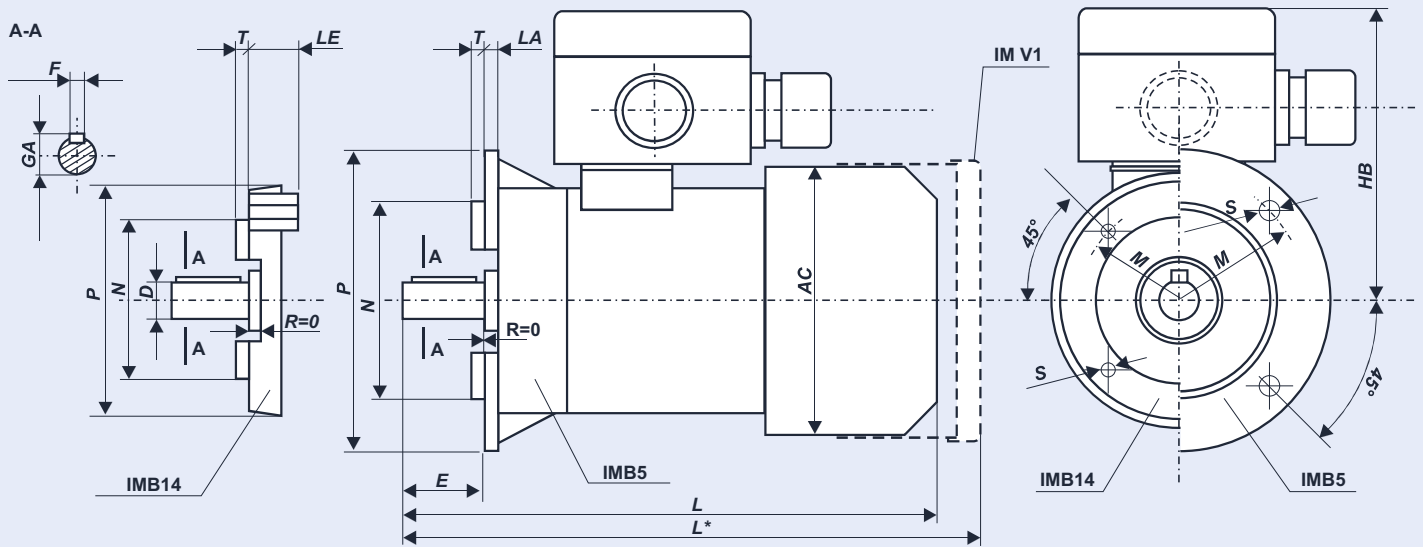

IM B5 / V1

Type of Motor	Flange	P	M	N	S	D	E	F	GA	LA	T	Gland	AC	HB	L/L*	Bearings
ExSKg56-A	B5	120	100	80j6	7	9j6	20	3h9	10,2	8	3	M20	117	120	188/214	6201 2Z
ExSKg56-B	B5	120	100	80j6	7	9j6	20	3h9	10,2	8	3	M20	117	120	214/222	6201 2Z
ExSKg63-A	B5	140	115	95j6	10	11j6	23	4h9	12,5	9	3	M20	126	114	201/227	6202 2Z
ExSKg63-B	B5	140	115	95j6	10	11j6	23	4h9	12,5	9	3	M20	126	114	213/239	6202 2Z
ExSKh71-A	B5	160	130	110j6	10	14j6	30	5h9	16	9	3,5	M20	141	119	223/249	6203 2Z
ExSKh71-B	B5	160	130	110j6	10	14j6	30	5h9	16	9	3,5	M20	141	119	245/271	6203 2Z
ExSKh80-A	B5	200	165	130j6	12	19j6	40	6h9	21,5	10	3,5	M20	157	127	266/283	6204 2Z
ExSKh80-B	B5	200	165	130j6	12	19j6	40	6h9	21,5	10	3,5	M20	157	127	278/303	6204 2Z
SKh90S-	B5	200	165	130j6	12	24j6	50	8h9	27	8	3,5	M20	185	130	305/329	6205 2Z
SKh90L-	B5	200	165	130j6	12	24j6	50	8h9	27	8	3,5	M20	185	130	330/354	6205 2Z
SKg100L-	B5	250	215	180j6	15	28j6	60	8h9	31	11	4	M20	206	140	376/421	6206 2Z
SKg112M-	B5	250	215	180j6	15	28j6	60	8h9	31	12	4	M25	245	164	384/429	6306 2Z
SKg132S-	B5	300	265	230j6	15	38k6	80	10h9	41	12	4	M25	274	198	463/516	6308 2Z
SKg132S-2B	B5	300	265	230j6	15	38k6	80	10h9	41	12	4	M25	274	198	501/554	6308 2Z
SKg132M-	B5	300	265	230j6	15	38k6	80	10h9	41	12	4	M25	274	198	501/554	6308 2Z
SKg160M-	B5	350	300	250j6	19	42k6	110	12h9	45	13	5	M40	323	210	612/665	6309 2Z
SKg160L-	B5	350	300	250j6	19	42k6	110	12h9	45	13	5	M40	323	210	656/709	6309 2Z
SKg180M-2	B5	350	300	250j6	19	48k6	110	14h9	51,5	13	5	M40	360	228	756/809	6311 2Z
SKg180M-4	B5	350	300	250j6	19	48k6	110	14h9	51,5	13	5	M40	360	228	705/758	6311 2Z
SKg180L-4	B5	350	300	250j6	19	48k6	110	14h9	51,5	13	5	M40	360	228	756/809	6311 2Z
SKg180L-6	B5	350	300	250j6	19	48k6	110	14h9	51,5	13	5	M40	360	228	705/758	6311 2Z

FLANGE MOUNTED MOTORS - IM B14 / V18

II 2G EExe II T3 -T4
 II 2D EExe II T3 -T4
 II 2G EExe II / II 2D T125°C

IM B14 / V18

Type of Motor	Flange	P	M	N	S	D	E	F	GA	LE	T	Gland	AC	HB	L/L*	Bearings
ExSKg56-.A1	B14C1	105	85	70j6	M6	9j6	20	3h9	10,2	15	2,5	M20	117	120	188/214	6201 2Z
ExSKg56-.A2	B14C2	80	65	50j6	M5	9j6	20	3h9	10,2	12,5	2,5	M20	117	120	188/214	6201 2Z
ExSKg56-.B1	B14C1	105	85	70j6	M6	9j6	20	3h9	10,2	15	2,5	M20	117	120	196/222	6201 2Z
ExSKg56-.B2	B14C2	80	65	50j6	M5	9j6	20	3h9	10,2	12,5	2,5	M20	117	120	196/222	6201 2Z
ExSKg63-.A1	B14C1	120	100	80j6	M6	11j6	23	4h9	12,5	14	3	M20	126	114	201/227	6202 2Z
ExSKg63-.A2	B14C2	90	75	60j6	M5	11j6	23	4h9	12,5	9,5	2,5	M20	126	114	201/227	6202 2Z
ExSKg63-.B1	B14C1	120	100	80j6	M6	11j6	23	4h9	12,5	14	3	M20	126	114	213/239	6202 2Z
ExSKg63-.B2	B14C2	90	75	60j6	M5	11j6	23	4h9	12,5	9,5	2,5	M20	126	114	213/239	6202 2Z
ExSKh71-.A1	B14C1	140	115	95j6	M8	14j6	30	5h9	16	14	3	M20	141	119	223/249	6203 2Z
ExSKh71-.A2	B14C2	105	85	70j6	M6	14j6	30	5h9	16	12	2,5	M20	141	119	223/249	6203 2Z
ExSKh71-.B1	B14C1	140	115	95j6	M8	14j6	30	5h9	16	14	3	M20	141	119	245/271	6203 2Z
ExSKh71-.B2	B14C2	105	85	70j6	M6	14j6	30	5h9	16	12	2,5	M20	141	119	245/271	6203 2Z
ExSKh80-.A1	B14C1	160	130	110j6	M8	19j6	40	6h9	21,5	14	3,5	M20	157	127	266/283	6204 2Z
ExSKh80-.A2	B14C2	120	100	80j6	M6	19j6	40	6h9	21,5	12	3	M20	157	127	266/283	6204 2Z
ExSKh80-.B1	B14C1	160	130	110j6	M8	19j6	40	6h9	21,5	14	3,5	M20	157	127	278/303	6204 2Z
ExSKh80-.B2	B14C2	120	100	80j6	M6	19j6	40	6h9	21,5	12	3	M20	157	127	278/303	6204 2Z
SKh90S-	B14C1	160	130	110j6	M8	24j6	50	8h9	27	10	3,5	M20	185	130	305/329	6205 2Z
SKh90S-	B14C2	140	115	95j6	M8	24j6	50	8h9	27	10	3	M20	185	130	305/329	6205 2Z
SKh90L-	B14C1	160	130	110j6	M8	24j6	50	8h9	27	10	3,5	M20	185	130	330/354	6205 2Z
SKh90L-	B14C2	140	115	95j6	M8	24j6	50	8h9	27	10	3	M20	185	130	330/354	6205 2Z
SKg100L-	B14C1	200	165	130j6	M10	28j6	50	8h9	31	10	3,5	M20	206	140	376/421	6206 2Z
SKg100L-	B14C2	160	130	110j6	M8	28j6	50	8h9	31	10	3,5	M20	206	140	376/421	6206 2Z
SKg112M-	B14C1	200	165	130j6	M10	28j6	60	8h9	31	12	3,5	M25	245	164	384/429	6206 2Z
SKg112M-	B14C2	160	130	110j6	M8	28j6	60	8h9	31	12	3,5	M25	245	164	384/428	6206 2Z
SKg132S-	B14C1	250	215	180j6	M12	38k6	80	10h9	41	12	4	M25	274	178	463/516	6208 2Z
SKg132S-	B14C2	200	165	130j6	M10	38k6	80	10h9	41	12	3,5	M25	274	178	463/516	6208 2Z
SKg132S-2B.	B14C1	250	215	180j6	M12	38k6	80	10h9	41	12	4	M25	274	178	501/554	6208 2Z
SKg132S-2B-	B14C2	200	165	130j6	M10	38k6	80	10h9	41	12	3,5	M25	274	178	501/554	6208 2Z
SKg132M-	B14C1	250	215	180j6	M12	38k6	80	10h9	41	12	4	M25	274	178	501/554	6208 2Z
SKg132M-	B14C2	200	165	130j6	M10	38k6	80	10h9	41	12	3,5	M25	274	178	501/554	6208 2Z
SKg160M-	B14C1	300	265	230j6	M12	42k6	110	12h9	45	13	4	M40	323	210	612/665	6209 2Z
SKg160M-	B14C2	250	215	180j6	M12	42k6	110	12h9	45	20	4	M40	323	210	612/665	6209 2Z
SKg160L-	B14C1	300	265	230j6	M12	42k6	110	12h9	45	13	4	M40	323	210	656/709	6209 2Z
SKg160L-	B14C2	250	215	180j6	M12	42k6	110	12h9	45	20	4	M40	323	210	656/709	6209 2Z

FOOT MOUNTED MOTORS - IMB 3 / V5

II 2D T 125°C

DIMENSION DRAWINGS

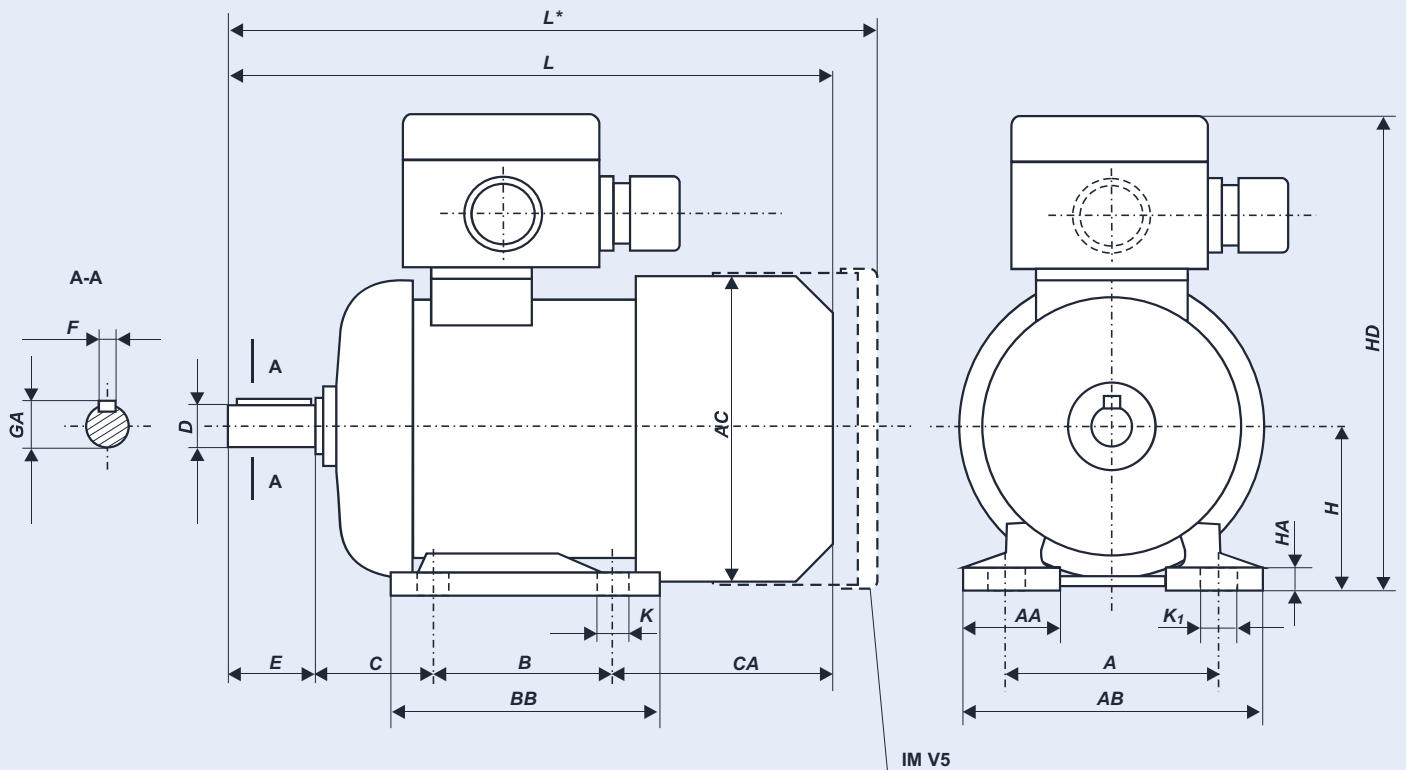

IM B3 / V5

Type of Motor	A	B	C	CA	D	E	F	GA	H	K	K1	Gland	AA	AB	AC	BB	HA	HD	L/L*	Bearings
Sh 90S ...	140	125	56	104	24j6	50	8h9	27	90	10	-	M20	50	170	185	153	10	220	305/329	6205 2Z
Sh 90L ...	140	125	56	104	24j6	50	8h9	27	90	10	-	M20	50	170	185	153	10	220	330/354	6205 2Z
Sg 100L ...	160	140	63	116	28j6	60	8h9	31	100	12	-	M20	45	200	206	172	14	240	376/421	6206 2Z
Sg 112M ...	190	140	70	119	28j6	60	8h9	31	112	12	-	M25	54	230	245	174	14	276	384/429	6306 2Z
Sg 132S ...	216	140	89	160	38k6	80	10h9	41	132	12	-	M25	56	278	274	182	16	310	463/516	6308 2Z
Sg 132S-2B	216	140	89	198	38k6	80	10h9	41	132	12	-	M25	56	278	274	220	16	310	501/554	6308 2Z
Sg 132M ...	216	178	89	160	38k6	80	10h9	41	132	12	-	M25	56	278	274	220	16	310	501/554	6308 2Z
Sg 160M ...	254	210	108	200	42k6	110	12h9	45	160	15	-	M40	60	305	323	256	20	370	612/665	6309 2Z
Sg 160L ...	254	254	108	200	42k6	110	12h9	45	160	15	-	M40	60	305	323	300	20	370	656/709	6309 2Z
Sg 180M ...	279	241	121	243	48k6	110	14h9	51,5	180	15	-	M40	70	350	360	320	26	408	705/758	6311 2Z
Sg 180L ...	279	279	121	205	48k6	110	14h9	51,5	180	15	-	M40	70	350	360	320	26	408	705/758	6311 2Z

FLANGE MOUNTED MOTORS - IM B5 / V1, IM B14 / V18

II 2D T 125°C

IM B5 / V1

Type of Motor	Flange	P	M	N	S	D	E	F	GA	LA	T	Gland	AC	HB	L/L*	Bearings
SKh 90S ...	B5	200	165	130j6	12	24j6	50	8h9	27	8	3,5	M20	185	130	305/329	6205 2Z
SKh 90L ...	B5	200	165	130j6	12	24j6	50	8h9	27	8	3,5	M20	185	130	330/354	6205 2Z
SKg 100L ...	B5	250	215	180j6	15	28j6	60	8h9	31	11	4	M20	206	140	376/421	6206 2Z
SKg 112M ...	B5	250	215	180j6	15	28j6	60	8h9	31	12	4	M25	245	164	384/429	6306 2Z
SKg 132S ...	B5	300	265	230j6	15	38k6	80	10h9	41	12	4	M25	274	178	463/516	6308 2Z
SKg 132S-2B	B5	300	265	230j6	15	38k6	80	10h9	41	12	4	M25	274	178	501/554	6308 2Z
SKg 132M ...	B5	300	265	230j6	15	38k6	80	10h9	41	12	4	M25	274	178	501/554	6308 2Z
SKg 160M ...	B5	350	300	250j6	19	42k6	110	12h9	45	13	5	M40	323	210	612/665	6309 2Z
SKg 160L ...	B5	350	300	250j6	19	42k6	110	12h9	45	13	5	M40	323	210	656/709	6309 2Z
SKg 180M ...	B5	350	300	250j6	19	48k6	110	14h9	51,5	13	5	M40	360	228	705/758	6311 2Z
SKg 180L ...	B5	350	300	250j6	19	48k6	110	14h9	51,5	13	5	M40	360	228	705/758	6311 2Z

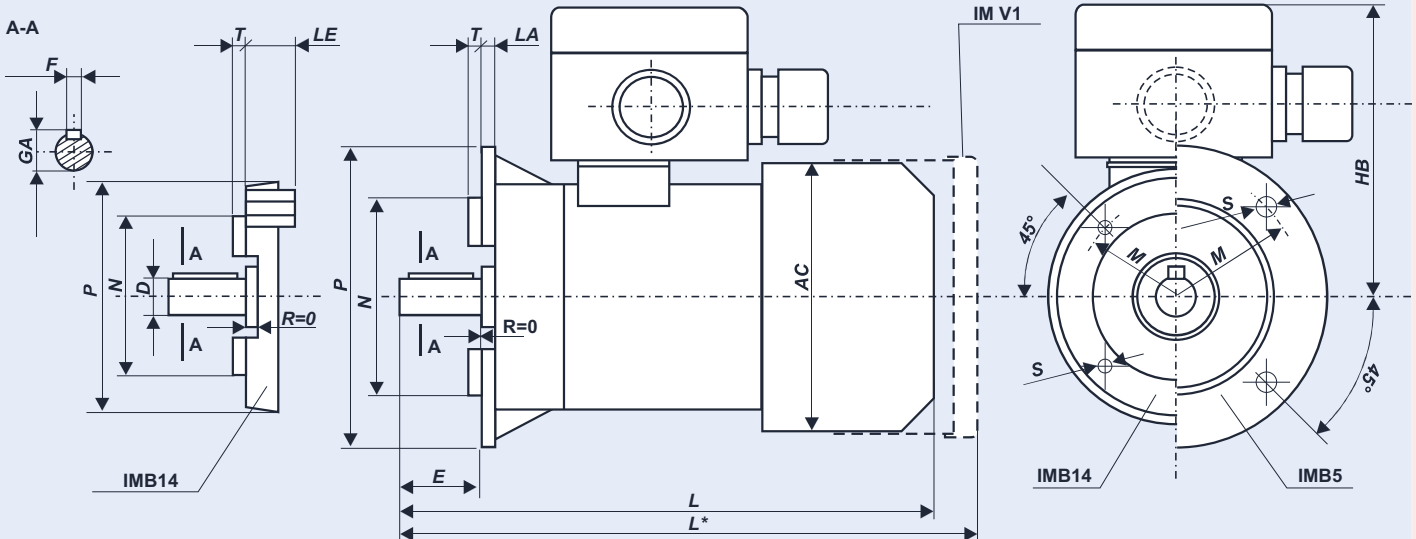

IM B14 / V18

Type of Motor	Flange	P	M	N	S	D	E	F	GA	LE	T	Gland	AC	HB	L/L*	Bearings
SKh 90S-	B14C1	160	130	110j6	M8	24j6	50	8h9	27	10	3,5	M20	185	130	305/329	6205 2Z
SKh 90S-	B14C2	140	115	95j6	M8	24j6	50	8h9	27	10	3	M20	185	130	305/329	6205 2Z
SKh 90L-	B14C1	160	130	110j6	M8	24j6	50	8h9	27	10	3,5	M20	185	130	330/354	6205 2Z
SKh 90L-	B14C2	140	115	95j6	M8	24j6	50	8h9	27	10	3	M20	185	130	330/354	6205 2Z
SKg 100L-	B14C1	200	165	130j6	M10	28j6	60	8h9	31	12	3,5	M20	206	140	376/421	6206 2Z
SKg 100L-	B14C2	160	130	110j6	M8	28j6	60	8h9	31	12	3,5	M20	206	140	376/421	6206 2Z
SKg 112M-	B14C1	200	165	130j6	M10	28j6	60	8h9	31	12	3,5	M25	245	164	384/429	6306 2Z
SKg 112M-	B14C2	160	130	110j6	M8	28j6	60	8h9	31	12	3,5	M25	245	164	384/429	6306 2Z
SKg 132S-	B14C1	250	215	180j6	M12	38k6	80	10h9	41	12	4	M25	274	178	463/516	6308 2Z
SKg 132S-	B14C2	200	165	130j6	M10	38k6	80	10h9	41	12	3,5	M25	274	178	463/516	6308 2Z
SKg 132S-2B	B14C1	250	215	180j6	M12	38k6	80	10h9	41	12	4	M25	274	178	501/554	6308 2Z
SKg 132S-2B	B14C2	200	165	130j6	M10	38k6	80	10h9	41	12	3,5	M25	274	178	501/554	6308 2Z
SKg 132M-	B14C1	250	215	180j6	M12	38k6	80	10h9	41	12	4	M25	274	178	501/554	6308 2Z
SKg 132M-	B14C2	200	165	130j6	M10	38k6	80	10h9	41	12	3,5	M25	274	178	501/554	6308 2Z
SKg 160M-	B14C1	300	265	230j6	M12	42k6	110	12h9	45	13	4	M40	323	210	612/665	6309 2Z
SKg 160M-	B14C2	250	215	180j6	M12	42k6	110	12h9	45	20	4	M40	323	210	612/665	6309 2Z
SKg 160L-	B14C1	300	265	230j6	M12	42k6	110	12h9	45	13	4	M40	323	210	656/709	6309 2Z
SKg 160L-	B14C2	250	215	180j6	M12	42k6	110	12h9	45	20	4	M40	323	210	656/709	6309 2Z

DIMENSION DRAWINGS

CANTONI
MOTOR



Cantoni Motor S.A.
Pańska 81/83
PL 00-834 Warsaw, Poland
tel. +48 22 652 84 05
fax +48 22 652 84 00
e-mail: motor@cantonimotor.com.pl
<http://www.cantonimotor.com.pl>